

NEW JERSEY STATE HIGHWAY ROUTE 37  
(R.O.W. VARIES)

SITE PLAN LEGEND

- (A) PROPOSED CONCRETE CURB (TYP.)
- (B) PROPOSED CONCRETE FLUSH CURB (TYP.)
- (C) PROPOSED CONCRETE SIDEWALK (TYP.)
- (D) PROPOSED NJDOT CONCRETE DEPRESSED CURB (TYP.)
- (E) PROPOSED REINFORCED CONCRETE PAD, 6" THICK.
- (F) PROPOSED CROSSWALK STRIPING (TYP.)
- (G) PROPOSED NJDOT CONCRETE CURB
- (H) LIGHT DUTY ASPHALT PAVEMENT (TYP.)
- (I) HEAVY DUTY ASPHALT PAVEMENT (TYP.)
- (J) PROPOSED 12" THK. STOP BAR WHITE STRIP (TYP.)
- (K) PROPOSED CLEARING LIMITS (TYP.)
- (L) PROPOSED PAINTED WHITE STRIPING, 4" THK. (TYP.)
- (M) PROPOSED STOP SIGN (R1-1)
- (N) PROPOSED CONCRETE APRON
- (O) PROPOSED - SITE I.D. SIGN
- (P) PROPOSED - "ENTRANCE" SIGN
- (Q) PROPOSED - "EXIT" SIGN
- (R) PROPOSED HANDICAP AND VAN ACCESSIBLE SIGNS
- (S) PROPOSED 6" BOLLARD
- (T) PROPOSED "NO PARKING FIRE LANE" SIGN
- (U) RELOCATED "ST. CATHERINE BLVD." KEEP RIGHT SIGN
- (V) PROPOSED TRASH ENCLOSURE
- (W) PROPOSED LIGHT POLE AND FIXTURE(S) (TYP.)
- (X) PROPOSED PARK BENCH (TYP.)
- (Y) PROPOSED LIMITS OF OVERHEAD CANOPY
- (Z) PROPOSED 4" WIDE WHITE-NO PARKING LOADING ZONE STRIPING
- (1) PROPOSED HANDICAP RAMP (PER A.D.A. REQUIREMENTS)
- (2) PROPOSED 4" WIDE WHITE-NO PARKING AREA STRIPING
- (3) PROPOSED "NO LEFT TURN" SIGN (R6-2)
- (4) PROPOSED "ONE WAY" SIGN (R6-1R)
- (5) PROPOSED 4" WIDE BRICK PAVEMENT WALKWAY
- (6) PROPOSED "DO NOT ENTER" SIGN (R5-1)
- (7) PROPOSED 4" BLUE-HANDICAP PARKING SIGN AND STRIPING
- (8) PROPOSED PAVEMENT TRAFFIC ARROW (TYP.)
- (9) PROPOSED 235 L.F. ALLEN BLOCK WALL
- (10) PROPOSED 4" WIDE YELLOW-NO PARKING FIRE LANE STRIPING
- (11) PROPOSED THERMOPLASTIC RUMBLE STRIP
- (12) PROPOSED 15'x50' SIGHT TRIANGLE
- (13) MATCH PROP. SIDEWALK TO EXIST. SIDEWALK
- (14) RELOCATE EXIST. UTILITY POLE
- (15) PROPOSED 6' HIGH CHAIN LINK FENCE
- (16) PROPOSED DECORATIVE LIGHT POST (TYP.)
- (17) PROPOSED DECORATIVE BRICK & CONCRETE SIDEWALK (SEE DETAIL)
- (18) PROPOSED "FIRE LANE" PAVEMENT MARKING (TYP.)
- (19) MATCH TO EXIST. CURBING
- (20) SAWCUT EXIST. PAVEMENT AND REMOVE EXIST CURB & PAVEMENT AN REPLACE AS NEEDED
- (21) SECURITY BOLLARD W/GRAY POLYETHYLENE COVER (TO WALGREENS SPEC.)
- (22) YELLOW DELINEATION POSTS AT DRIVE UP WINDOW FASTENED TO CONC. WITH BOLTS (TO WALGREENS SPEC.)
- (23)

GRAPHIC SCALE

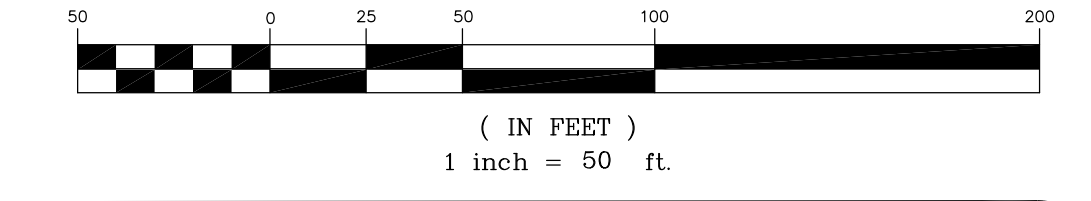

REV.	DATE	DESCRIPTION	BY
12.	2/27/07	REV. PER RESOLUTION	MFC
11.	8/30/06	REV. AS PER WALGREENS MODIFICATIONS	MFM
10.	9/07/05	REV. PER ADDITIONAL SPOT GRADE INFORMATION @ RETAIL PAD	MFM
9.	7/28/05	REV. WATER MAIN LOCATION AND BLDG PAD LAYOUT	MFM
8.	7/14/04	REV. PER DOVER TOWNSHIP FIRE OFFICIAL LETTER DATED: 6/21/04	MFM
7.	6/10/04	REV. PER DOVER TOWNSHIP ENVIRONMENTAL	MFM
6.	5/26/04	REV. PER DOVER TOWNSHIP ENVIRONMENTAL	TRL
5.	5/07/04	REV. PER RESOLUTION COMPLIANCE LETTER DATED: 4/07/04	MFM
4.	2/16/04	REV. PER DTMLIA REVIEW LETTER DATED: 1/27/04	TRL
3.	1/21/04	REV. PER CAFRA COMMENTS	TRL
2.	12/23/03	REV. PER CLIENTS REQUEST BLDG./ PARKING	MFM
1.	12/03/03	REV. PER 11/10/03 PLANNING BOARD HEARING	MFM

AMENDED PRELIMINARY AND FINAL MAJOR SITE PLAN  
FOR  
**THE ORCHARDS AT DOVER**  
SITE PLAN  
TAX MAP LOT 9.02 BLOCK 506.01  
DOVER TOWNSHIP  
OCEAN COUNTY NEW JERSEY



**STEPHEN P. ATKINS, P.E.**  
PROFESSIONAL ENGINEER  
N.J. P.E. LICENSE No. 37849

DRAWN (CHK'D) DATE SCALE FILE CALC. DWG./SET No.  
MFM S.A. 7/16/03 1"=50' 020616 3 OF 10

LEGEND

EXISTING	PROPOSED	EXISTING	PROPOSED
CONCRETE CURB	→	MANHOLE	○
TRAFFIC FLOW	→	TYPE "B" INLET	○
I.D. SIGN	○	8" x 12" INLET	○
SON	○	8" x 12" INLET	○
UNDER AND OUT SIGNS	→	8" x 12" INLET	○
POLE MOUNTED LIGHT	○	8" x 12" INLET	○
UTILITY POLE	○	8" x 12" INLET	○
TRANSFORMER	○	8" x 12" INLET	○
CHAIN FENCE	—	8" x 12" INLET	○
8" x 12" INLET	○	8" x 12" INLET	○
RETAINING WALL	—	8" x 12" INLET	○
BUILDING DISTANCE	—	8" x 12" INLET	○
FIRE HYDRANT	○	8" x 12" INLET	○
WATER VALVE	○	8" x 12" INLET	○
CONTOUR	—	8" x 12" INLET	○

OCEAN COUNTY PLANNING BOARD  
FINAL SITE PLAN APPROVAL  
DATE 8/6/03  
[Signature]  
CHAIRMAN

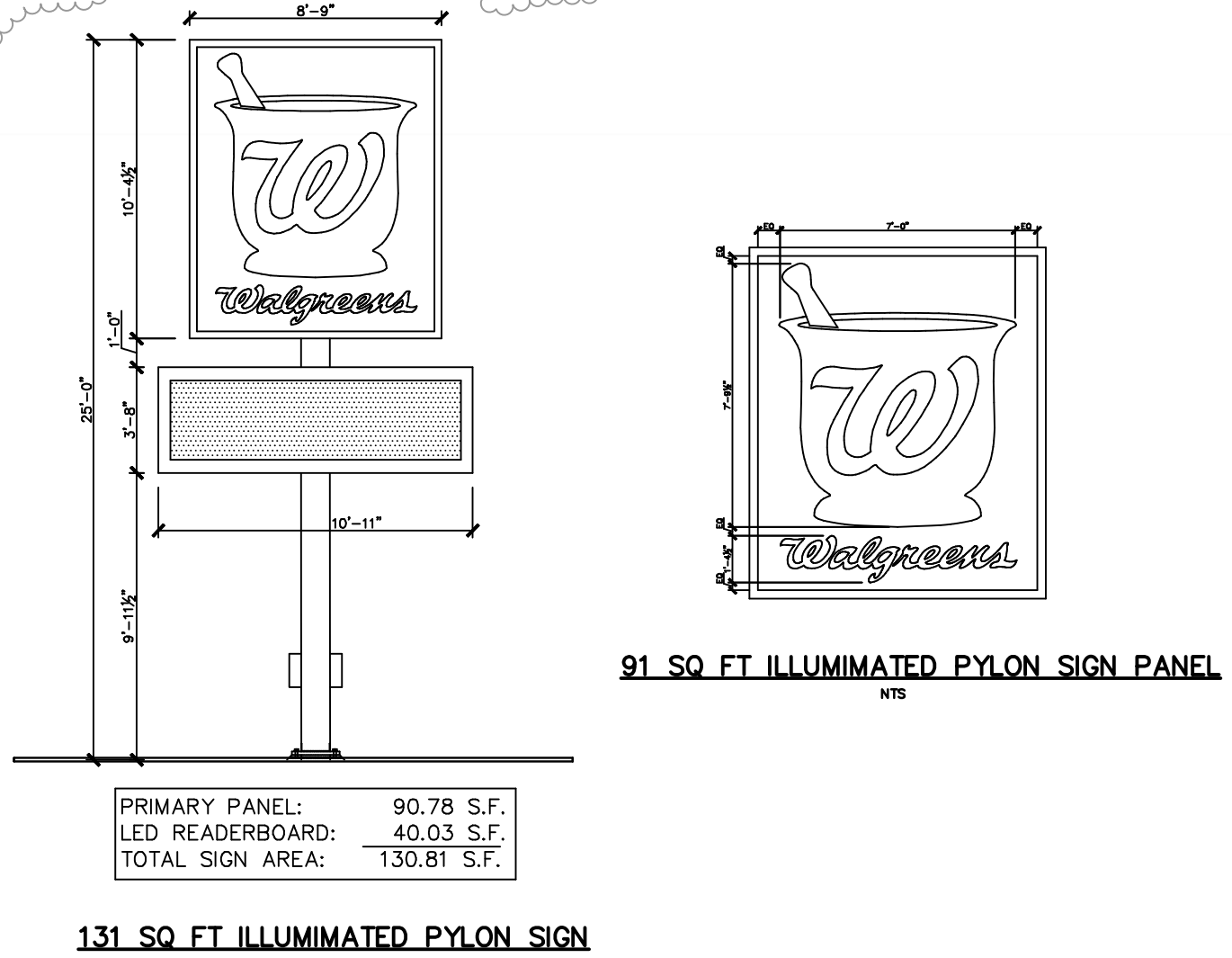

SIGN TABLE - PROPOSED WALGREENS

FACADE	SIGNABLE AREA (SF)	PROPOSED SIGNAGE	SIGN AREA	% SIGNABLE AREA	TOTAL ITEMS OF INFO
EAST	1920.77 SF	EXIT	2.1 SF		
		TOTAL	2.1 SF	< 1.0%	
WEST	1735.80 SF	DRIVE THRU WALGREENS PHARMACY PHOTO 24 HOUR	12.6 SF 95.36 SF 11.6 SF 9.3 SF	8.5%	
		TOTAL	148.06 SF		
NORTH	1836.89 SF	WALGREENS PHARMACY PHOTO 24 HOUR	95.36 SF 11.6 SF 9.3 SF	7.4%	
		TOTAL	135.46 SF		
TOTAL WALGREENS BUILDING SIGNAGE			285.62 SF		

OWNER MAY MAKE AND RETAIN COPIES OF DOCUMENTS, PLANS AND SPECIFICATIONS ETC., FOR INFORMATION AND REFERENCE IN CONNECTION WITH USE OF THE PROJECT BY OWNER. SUCH DOCUMENTS ARE NOT INTENDED OR REPRESENTED TO BE SUITABLE FOR REUSE BY OWNER OR OTHERS ON EXTENSIONS OR MODIFICATIONS OF THE PROJECT OR ON ANY OTHER PROJECT. ANY SUCH REUSE OR MODIFICATION WITHOUT WRITTEN PERMISSION, VERIFICATION OR ADAPTATION BY ENGINEER IS APPROPRIATE FOR THE STRICT PURPOSE INTENDED AND WILL BE AT OWNER'S SOLE RISK AND WITHOUT LIABILITY OR LEGAL EXPOSURE TO ENGINEER OR ENGINEER'S CONSULTANTS. OWNER SHALL INDEMNIFY AND HOLD HARMLESS ENGINEER AND ENGINEER'S CONSULTANTS FROM ALL CLAIMS, DAMAGES, LOSSES AND EXPENSES, INCLUDING ATTORNEY'S FEES ARISING OUT OF OR RESULTING THEREFROM.

PLEASE SEE "RETAIL SPACE AVAILABLE" LINK ON PROPERTY PAGE FOR ALL CURRENT TENANCIES.